

WIRE / CAVI		FORK TERMINALS TERMINALI A FORCHETTA	
FLEXIBLE FLESSIBILE	SOLID RIGIDO	10mm2 AWG = 10	16mm2 AWG = 8
mm2 = 2x6 AWG = 10	mm2 = 2x6 AWG = 10	mm2 = 1x10 AWG = 8	mm2 = 1x16 AWG = 6

TIGHTENING TORQUE = 1,7 Nm  
COPPIA SERRAGGIO VITI

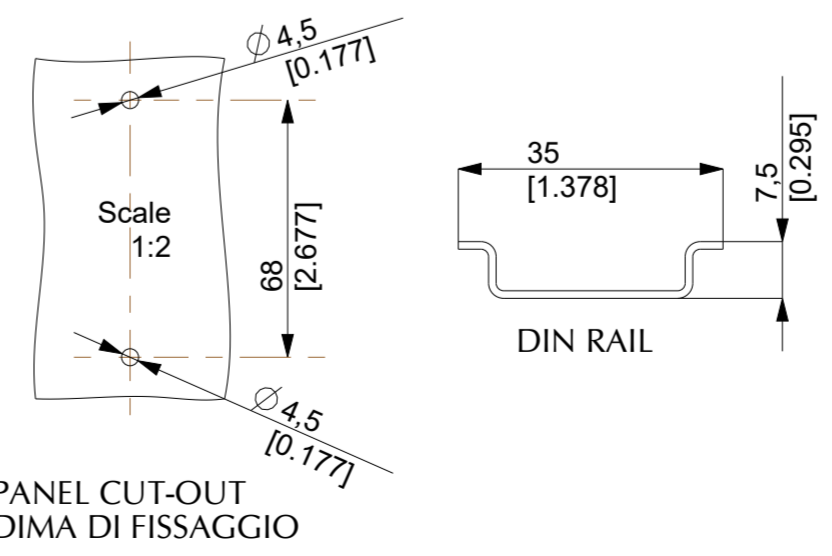
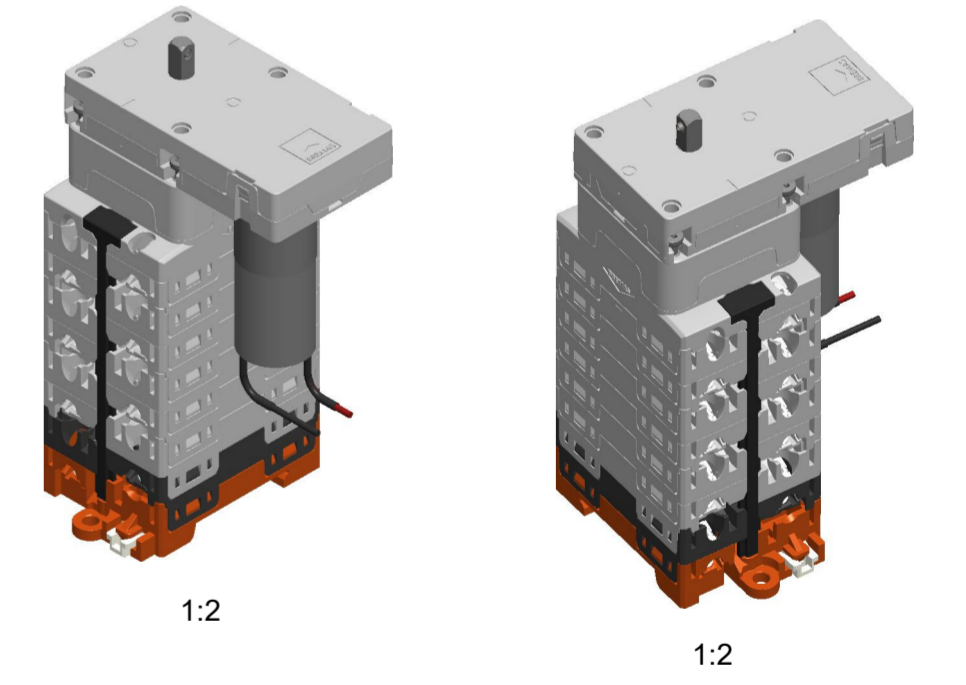
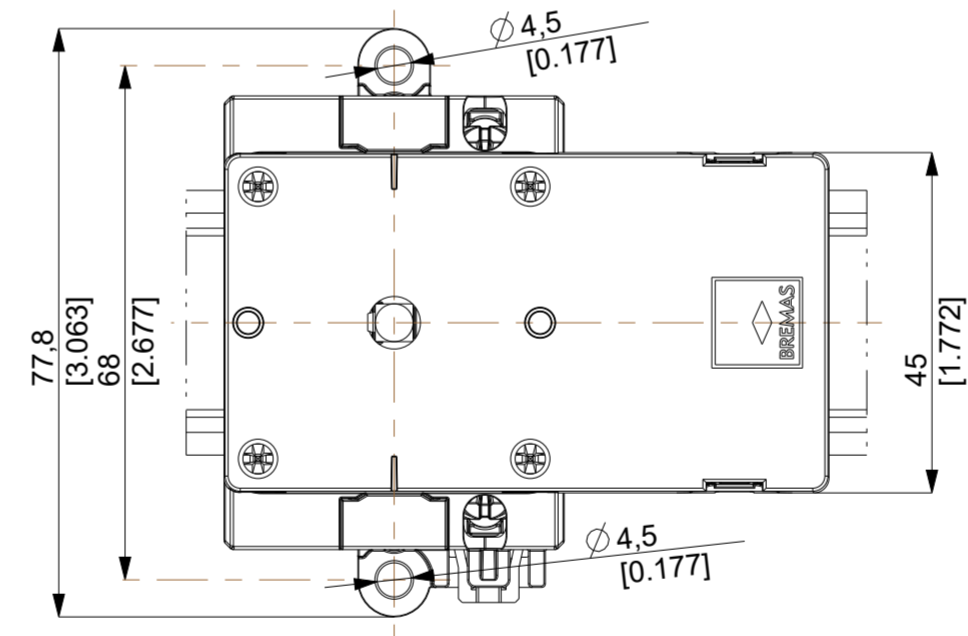
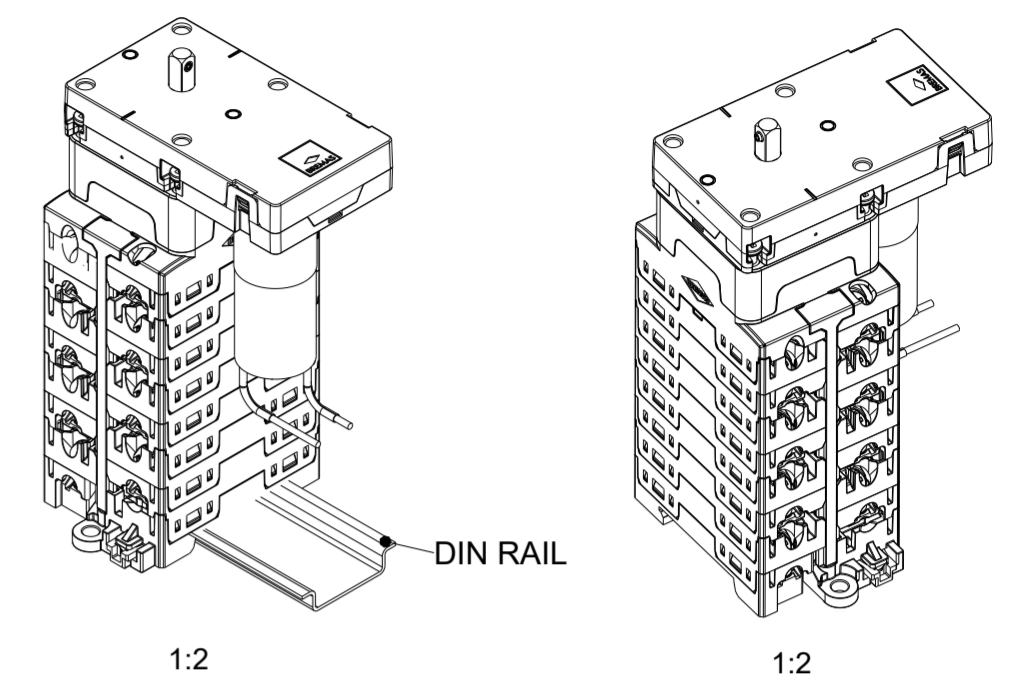
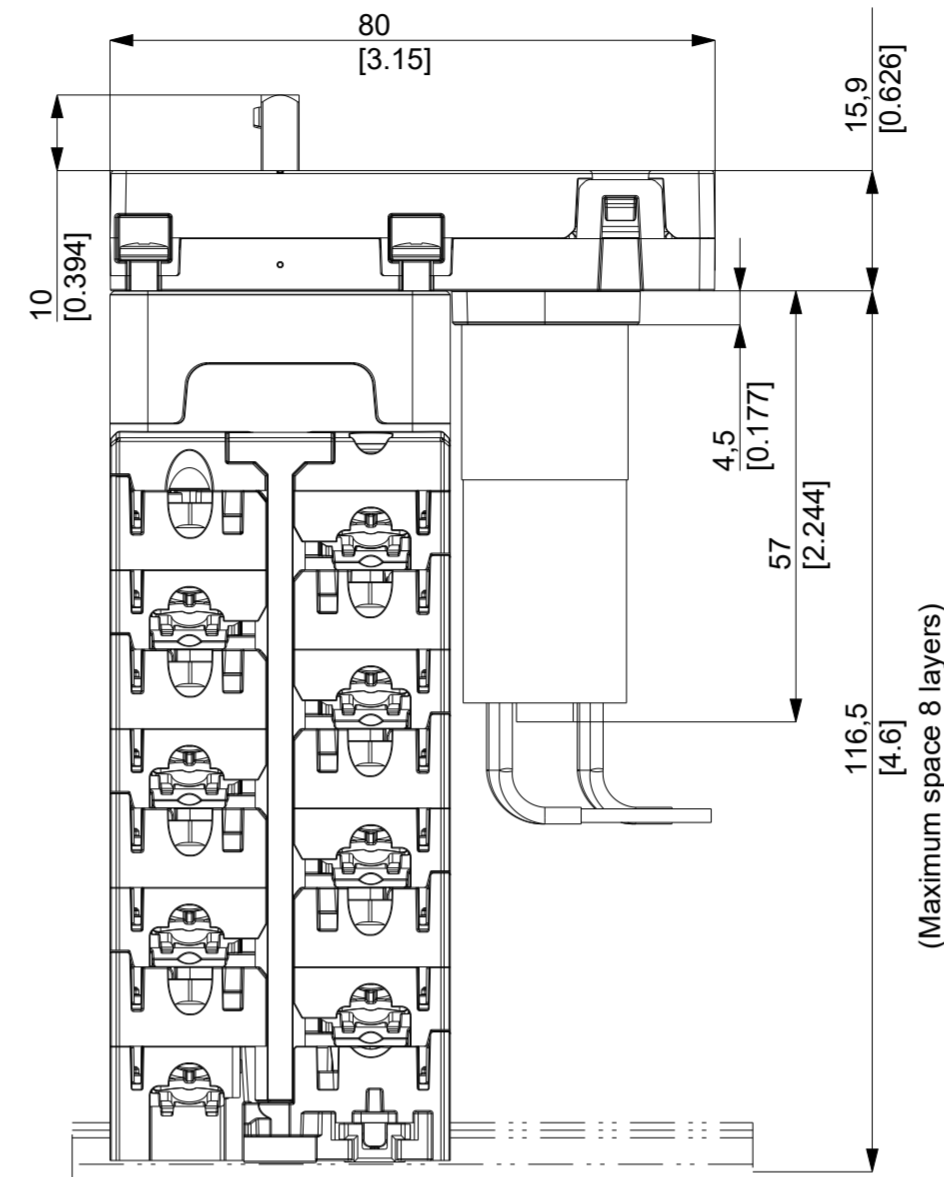
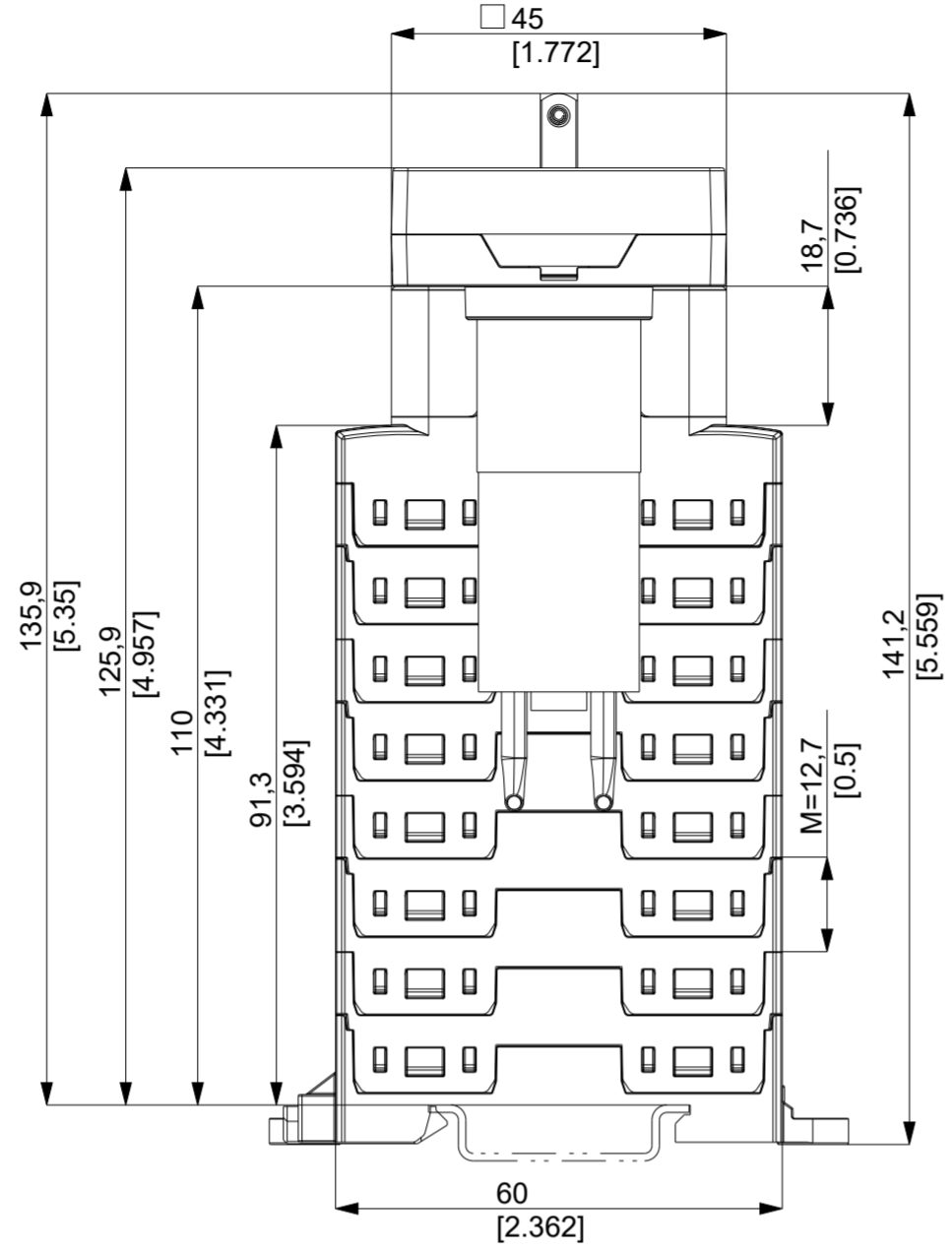

Dimension in mm in [inch]      Dimensioni in mm in [pollici]

EDIZ./REL		MODIFICA / REVISION				DATA/DATE	SIGLA/SIGN
MATERIALE / MATERIAL: --		FINITURA / FINISHING: --					
Dis/Drw F. Civettini		Impiego Use	Scala Scale	Toll. Gen. Tol.	Sost./Rep.the		
Contr/Cxd		CM+DXU	1:1	Lineare/Linear Is12	Sost./Rep.of		
Data/Date: Jul-04-24				Angoli/Angles: 30	Direttorio/Directory		
OGGETTO/OBJECT: DXU WITH MOTOR SHAFT PR.10 FIXING DDN - 3MPPT							EDIZ./REL 1
						DISEGNO / DRAWING CM_DXU8W_A_SP10	

QUESTO DISEGNO NON PUO' ESSERE RIPRODOTTO NE MOSTRATO A TERZE PERSONE ART.115-33 C.C.-289 C.P.